

SWITCHCRAFT® SYSTEM

REVISIONS

ZONE	REV	DESCRIPTION	DATE	APPROVED
------	-----	-------------	------	----------

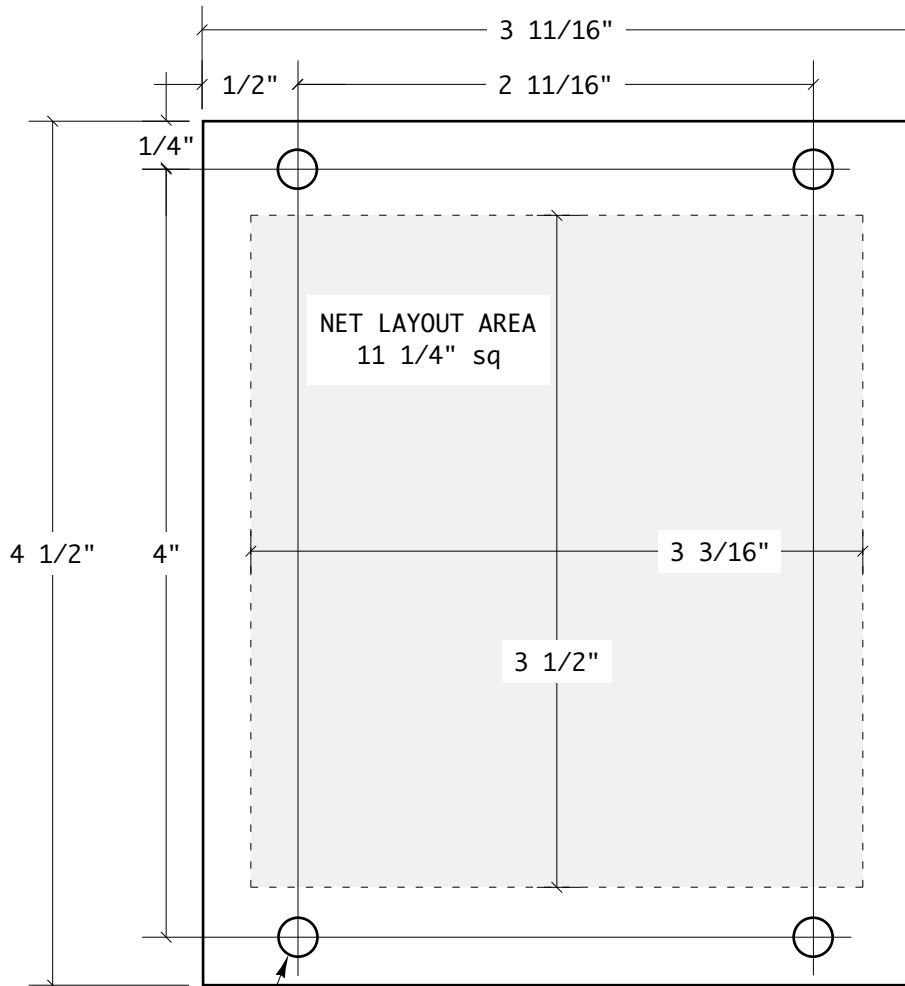

13/64" Diameter  
(4) Places

Made from high strength aluminum alloy (6061-T6), 1/16" thick. Finished with oven-cured semi-gloss black powder coat.

ALL DIMENSIONS ARE FOR REFERENCE ONLY. UNLESS OTHERWISE SPECIFIED ALL DIMENSIONS ARE IN INCHES.

APPROVALS

DATE



**ACE BACKSTAGE CO., INC. - STAGE POCKET SYSTEMS**  
24846 Avenue Rockefeller • Suite 200 • Valencia, CA 91355  
Tel: 661-295-5760 • Fax: 661-295-1122 • Web: www.acebackstage.com

DRAWN

04/22/08

ENGINEER

TITLE

**#PSW-100 SWITCHCRAFT® PANEL, BLANK**

TREATMENT

CHECKED

FINISH

APPROVED

SIZE  
**A**

DWG NO. **PSW-100.pdf**

REV

SIMILAR TO

MARKING SYMBOL

ISSUED

SCALE: 1:1

SWITCHCRAFT® POCKET PANEL

SHEET 1 OF 1