

FULL POCKET

122 / 222 / 322

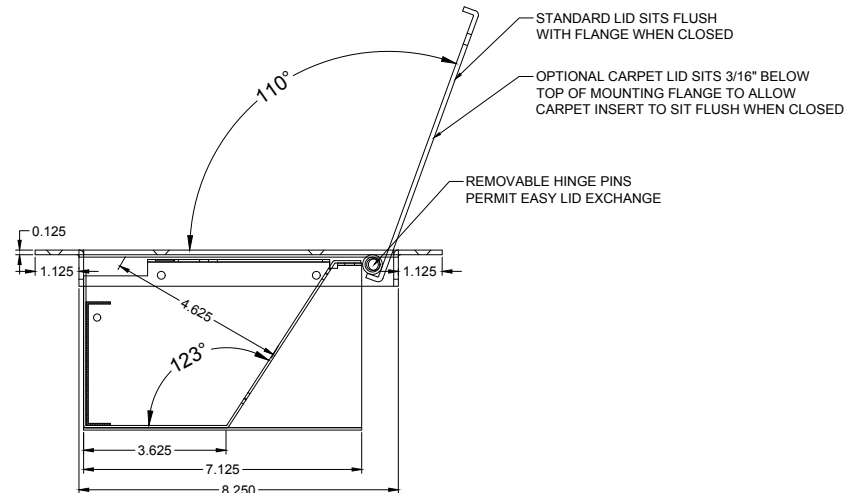
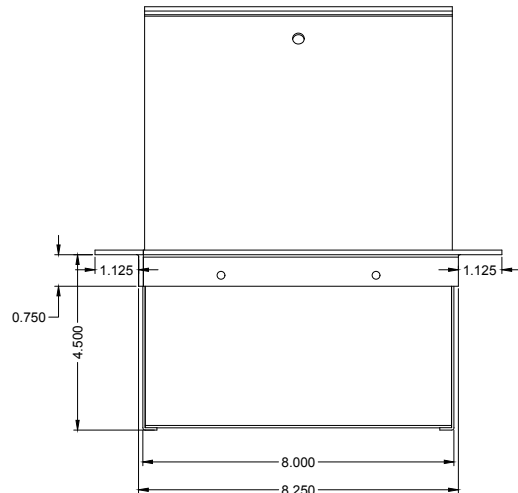
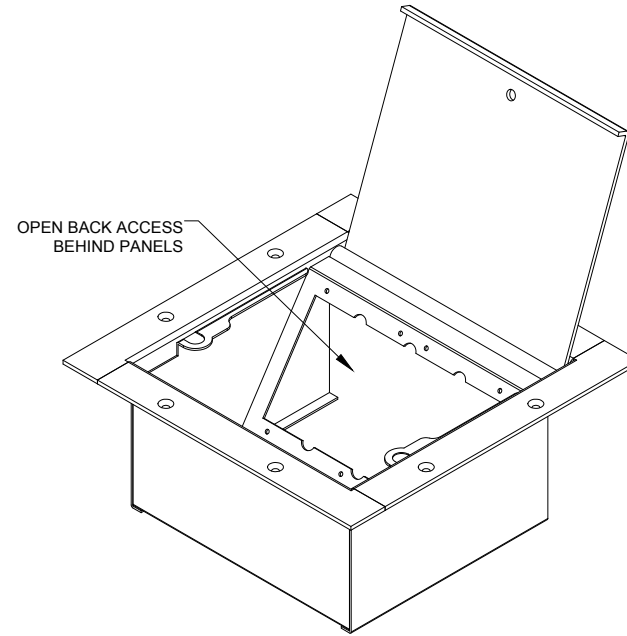
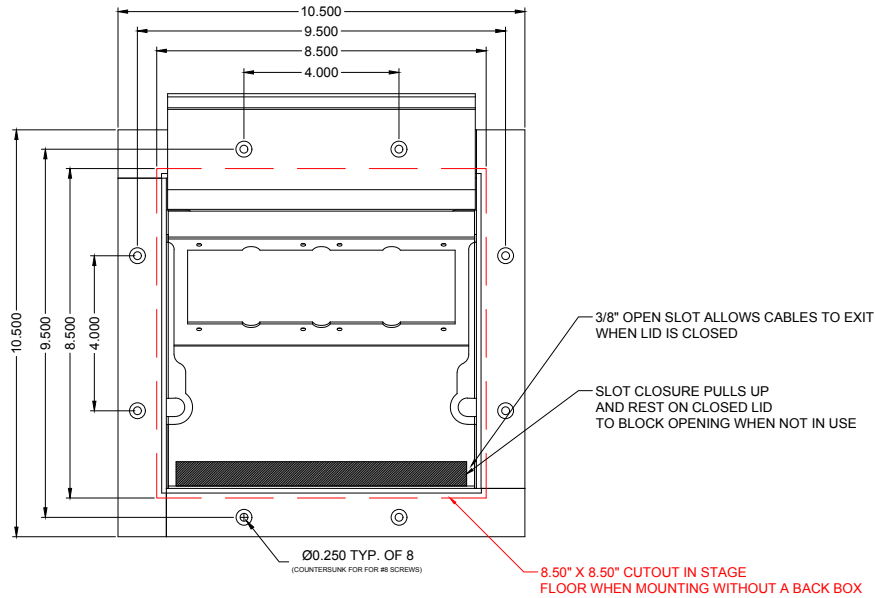

REVISION: 11/2019

BEZEL/LID FINISH CHOICES:

- Textured Black Electrostatic Powder Coat
- Coppervein Electrostatic Powder Coat
- Solid Brushed Brass
- Solid Brushed Stainless Steel

CAPACITY:

Up to (12) Connectors
OR (1-6) Connectors and (1) AC Duplex.
Compatible with **CONNECTRIX** Panels and Connectors.

DESCRIPTION:

Heavy Duty Full, Slant Panel, Stage Pocket with choice of Lid and Finish. Pocket Body made from 16ga CRS with 11ga Lid and Flange from CRS or half hard Brass or Stainless Steel.

REV
1
SHEET
1 OF 1