

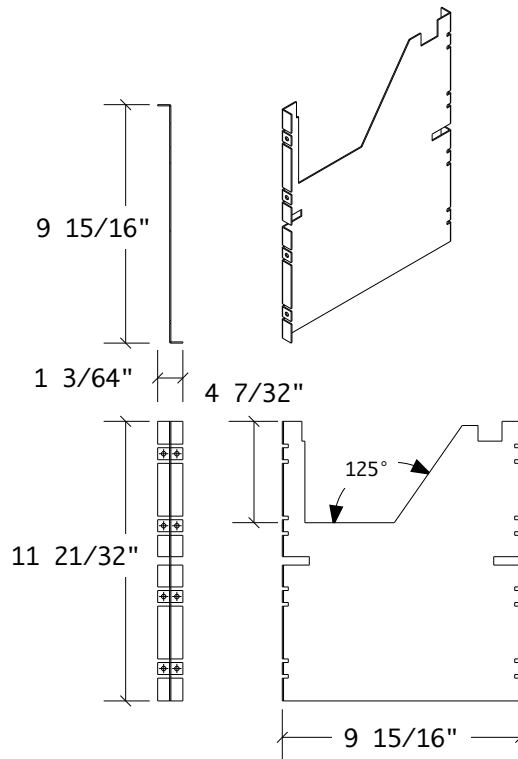

VERTICAL SLANT PANEL

REVISIONS

ZONE	REV	DESCRIPTION	DATE	APPROVED
------	-----	-------------	------	----------



ALL DIMENSIONS ARE FOR REFERENCE ONLY. UNLESS OTHERWISE SPECIFIED ALL DIMENSIONS ARE IN INCHES.

APPROVALS

DATE



ACE BACKSTAGE CO., INC. - STAGE POCKET SYSTEMS
 24846 Avenue Rockefeller • Suite 200 • Valencia, CA 91355
 Tel: 661-295-5760 • Fax: 661-295-1122 • Web: www.acebackstage.com

DRAWN

04/22/08

ENGINEER

TITLE

#ISOBRKT12 12" ISOLATION BRACKET FOR FULL STAGE POCKET(S)/DOUBLE DEEP BACK BOX(ES)

TREATMENT

CHECKED

FINISH

APPROVED

SIZE

A

DWG NO.

ISOBRKT12.pdf

REV

SIMILAR TO

MARKING SYMBOL

ISSUED

SCALE: 1:8

AC ISOLATION BRACKETS

SHEET 1 OF 1