

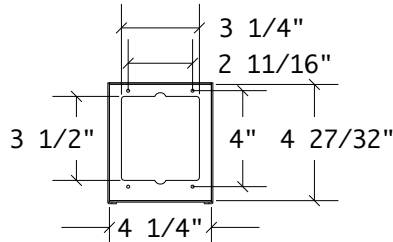

VERTICAL SLANT PANEL

REVISIONS

| ZONE | REV | DESCRIPTION | DATE | APPROVED |
|------|-----|-------------|------|----------|
|------|-----|-------------|------|----------|

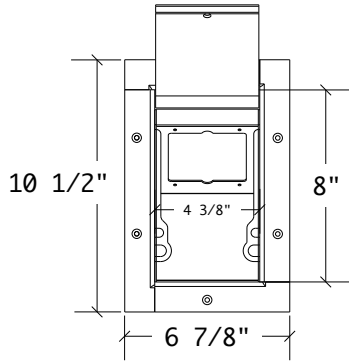

SECTION A-A
(rotated 55° clockwise)

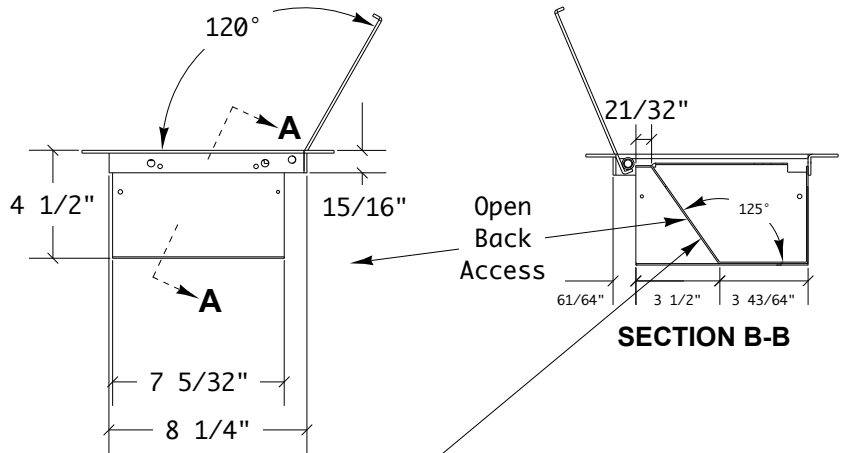
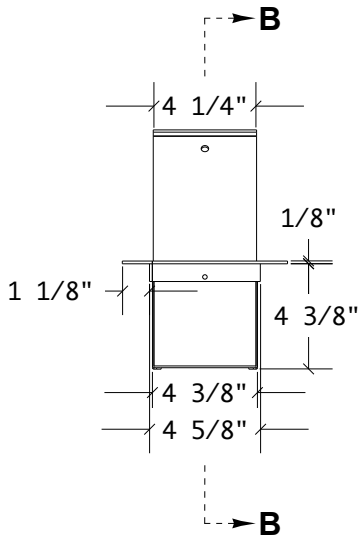
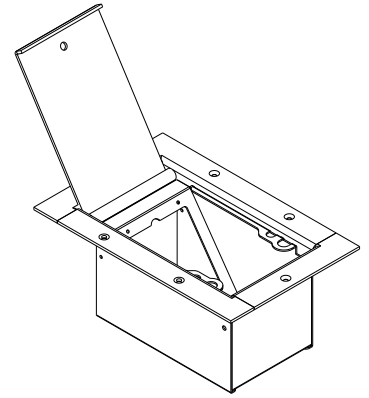

SECTION B-B



ALL DIMENSIONS ARE FOR REFERENCE ONLY. UNLESS OTHERWISE SPECIFIED ALL DIMENSIONS ARE IN INCHES.

APPROVALS

DATE



ACE BACKSTAGE CO., INC. - STAGE POCKET SYSTEMS
24846 Avenue Rockefeller • Suite 200 • Valencia, CA 91355
Tel: 661-295-5760 • Fax: 661-295-1122 • Web: www.acebackstage.com

DRAWN

04/22/08

ENGINEER

TITLE

#123XXXX HALF STAGE POCKET

TREATMENT

CHECKED

FINISH

APPROVED

SIZE
A

DWG NO.

123xxxx.pdf

REV

SIMILAR TO

MARKING SYMBOL

ISSUED

SCALE: 1:8

HALF POCKET

SHEET 1 OF 1