

HALF BACK BOX



COMPATIBLE WITH:
VERTICAL SLANT POCKET



PROUDLY MADE
IN THE U.S.A.

REVISIONS

REV

DESCRIPTION

DATE



ACE BACKSTAGE CO., INC. - STAGE POCKET SYSTEMS

www.acebackstage.com

COMPATIBLE POCKETS:

MODEL NUMBERS:	DESCRIPTION:
123SLBK	STANDARD LID / BLACK
123CLBK	CARPET LID / BLACK
123SLCV	STANDARD LID / COPPER VEIN
123CLCV	CARPET LID / COPPER VEIN
223SLBR	STANDARD LID / SOLID BRASS
223CLBR	CARPET LID / SOLID BRASS
323SLSS	STANDARD LID / STAINLESS STEEL
323CLSS	CARPET LID / STAINLESS STEEL

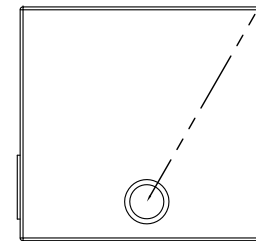
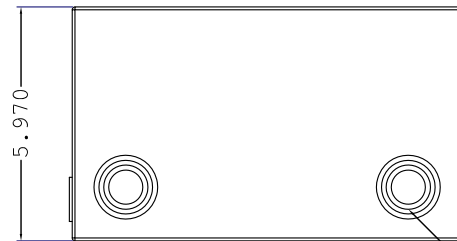
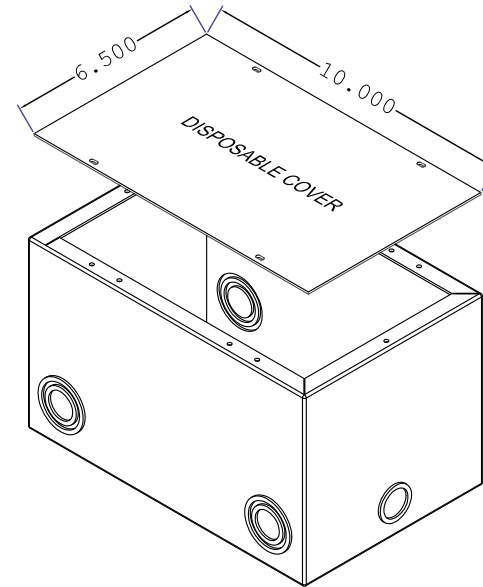
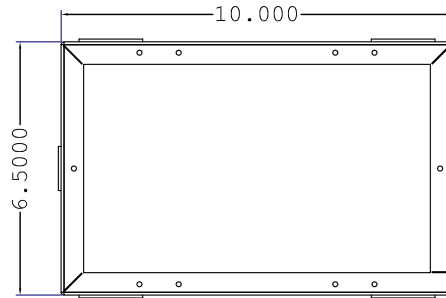

1/2" AND 3/4" COMBINATION KNOCKOUTS
(1) PLACE TYPICAL ON OPPOSING SIDES

1/2", 3/4", 1", AND 1-1/4" COMBINATION
KNOCKOUTS (2) PLACES TYPICAL ON
OPPOSING SIDES.

APPROVALS

DATE

DRAWN

JM

08/04/11

CUSTOMER APPROVAL



ALL DIMENSIONS ARE FOR
REFERENCE ONLY. UNLESS
OTHERWISE SPECIFIED ALL
DIMENSIONS ARE IN INCHES.

FINISH

ELECTRO DEPOSITED CLEAR ZINC

MATERIAL

14 GAUGE CRS

ITEM:

103BBX

DESCRIPTION:

6" DEEP BACK BOX FOR USE WHEN INSTALLING
HALF SIZE POCKETS.

REV

1

SHEET

1 OF 1